

(No Model.)

3 Sheets—Sheet 1.

G. R. IBACH & J. H. SCHULTZ.  
ATTACHMENT FOR LATHES.

No. 488,815.

Patented Dec. 27, 1892.

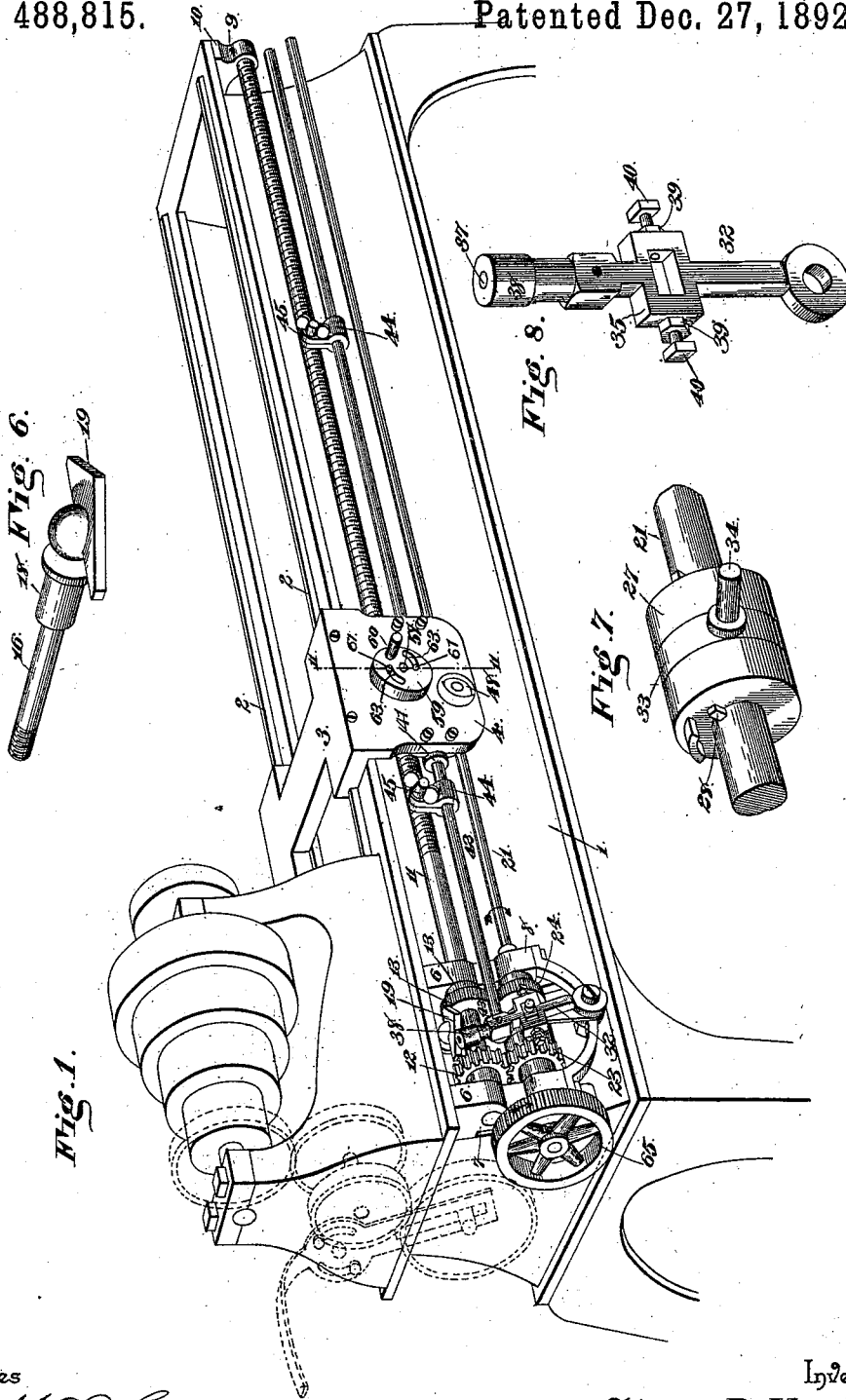

Witnesses

*M. E. Fowler*  
*W. S. Duwall.*

Inventors

*Gideon R. Ibach*  
*John H. Schultz*

By their Attorneys,

*C. A. Snow & Co.*

(No Model.)

3 Sheets—Sheet 2.

# G. R. IBACH & J. H. SCHULTZ.

ATTACHMENT FOR LATHES.

No. 488,815.

Patented Dec. 27, 1892.

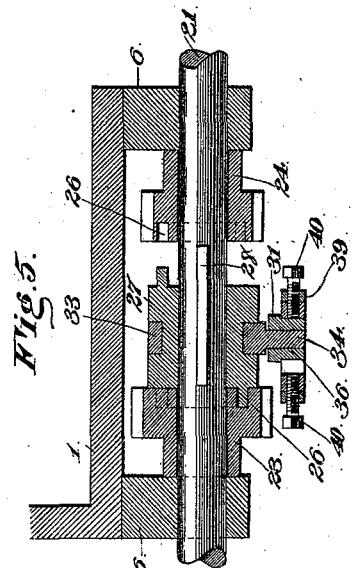
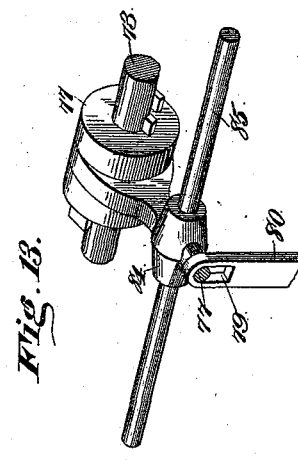
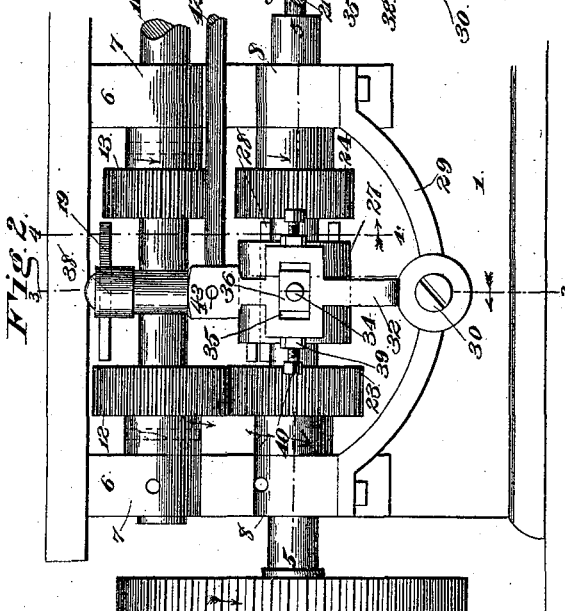
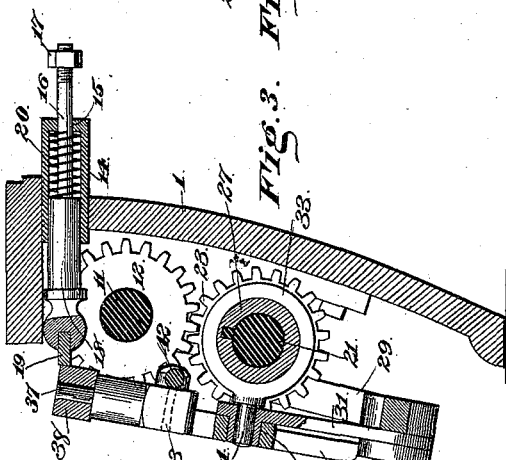
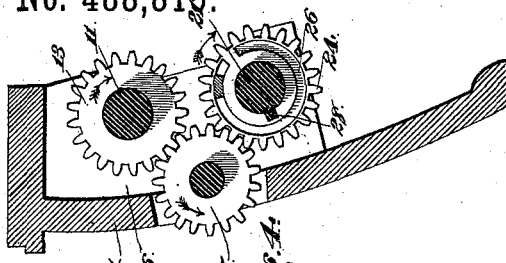

Witnesses

*M. Fowler*  
*W. S. Duwall*

By their Attorneys,

*C. Snow & Co.*

Inventors  
*Gideon R. Ibach*  
*John H. Schultz*

(No Model.)

3 Sheets—Sheet 3.

G. R. IBACH & J. H. SCHULTZ.  
ATTACHMENT FOR LATHES.

No. 488,815.

Patented Dec. 27, 1892.

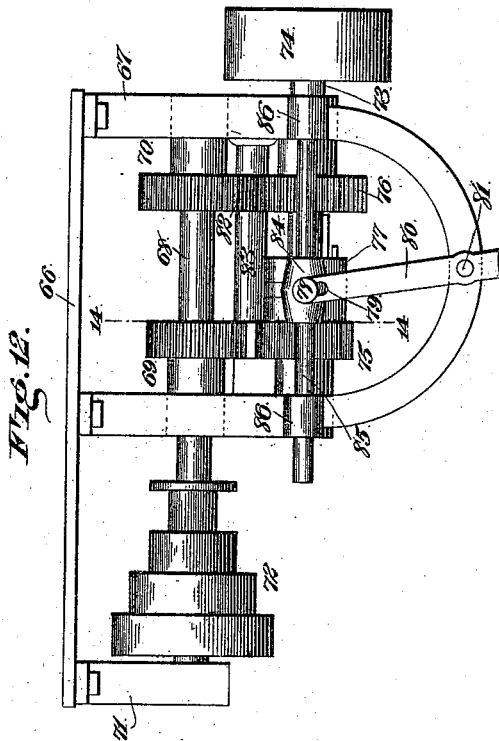
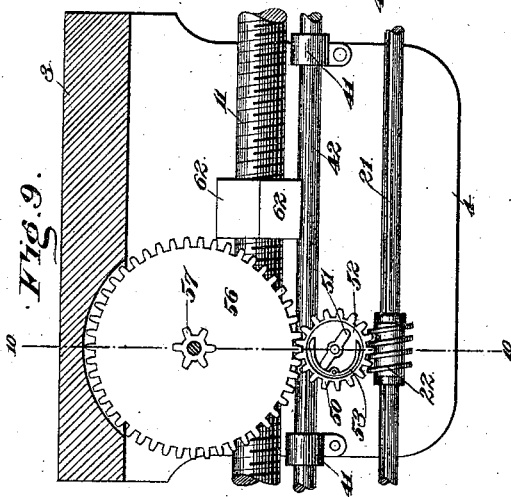
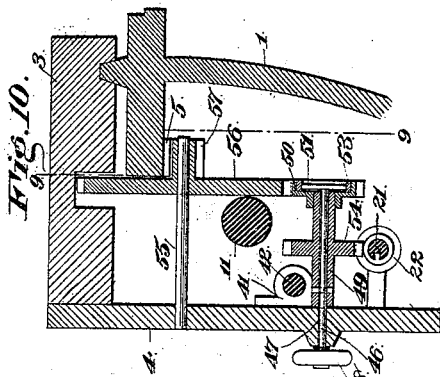
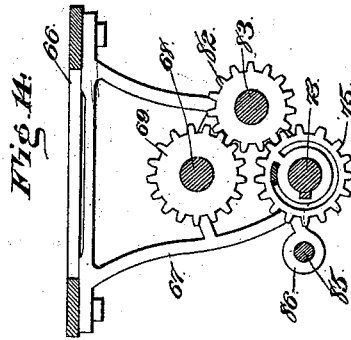
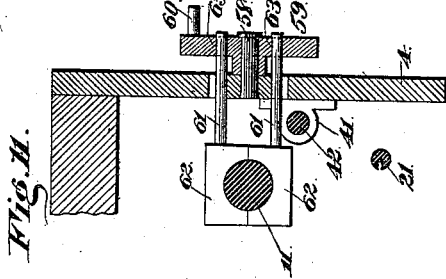

Witnesses

*M. Fowler*  
*W. S. Duwall*

Inventors

*Gideon R. Ibach*  
*John H. Schultz*

By their Attorneys,

*C. Snow & Co.*

# UNITED STATES PATENT OFFICE.

GIDEON R. IBACH AND JOHN H. SCHULTZ, OF BROOKLYN, NEW YORK.

## ATTACHMENT FOR LATHES.

SPECIFICATION forming part of Letters Patent No. 488,815, dated December 27, 1892.

Application filed January 11, 1892. Serial No. 417,733. (No model.)

*To all whom it may concern:*

Be it known that we, GIDEON R. IBACH and JOHN H. SCHULTZ, citizens of the United States, residing at Green Point, Brooklyn, in the county of Kings and State of New York, have invented a new and useful Attachment for Lathes, of which the following is a specification.

This invention relates to improvements in lathes; the objects in view being to provide means for accurately regulating the travel of the carriage in cutting screw threads, and to provide for an automatic shifting of the same at the end of its travel; and furthermore to provide means for throwing the shifting mechanism and carriage-feed mechanism out of operative position and adapt the carriage to be fed to any point along the lathe as during the operation of boring and turning, and to accomplish such feeding through the medium of the same mechanism employed for feeding the carriage during the operation of screw-cutting.

With these main objects in view, the invention consists in certain novel features of construction hereinafter specified and particularly pointed out in the claims.

Referring to the drawings—Figure 1 is a perspective of a lathe embodying our improvements. Fig. 2 is a front elevation of the gearing employed for operating the screw feed-rod. Fig. 3 is a vertical section on the line 3—3 of Fig. 2. Fig. 4 is a similar view on the line 4—4 of Fig. 2. Fig. 5 is a longitudinal horizontal section on the line 5—5 of Fig. 2. Fig. 6 is a detail in perspective of the spring-pressed shifting cam-plunger. Fig. 7 is a detail in perspective of the reciprocating-clutch. Fig. 8 is a detail in perspective of the shifting-lever. Fig. 9 is a vertical section on the line 9—9 of Fig. 10, the section being taken through the carriage, looking from the rear. Fig. 10 is a vertical transverse section on the line 10—10 of Fig. 9. Fig. 11 is a vertical section on the line 11—11 of Fig. 1. Fig. 12 is a front elevation of our invention, embodied in a countershaft, in lieu of directly applying it to the lathe. Fig. 13 is a detail in perspective of the clutch employed therein. Fig. 14 is a section on the line 14—14 of Fig. 12.

Like numerals of reference indicate like parts in all the figures of the drawings.

1 designates the lathe-bed, and the same is provided with the usual ways 2, upon which for longitudinal reciprocation is mounted the tool-carrying carriage 3, the front of which depends in front of and some little distance from the lathe, thus forming a depending apron. The under side of the front ledge of the base is, as usual, provided with the rack-bar 5, over which the apron 4 depends.

To the left-hand side of the front wall of the base 1 there is mounted a pair of brackets 6, each of which is provided with an upper and a lower bearing 7 and 8 respectively. In line with the bearings 7, at the opposite or right-hand end of the machine, a bearing-opening 9 is formed in the depending bracket 10, and in the bearings 7 and 9 there is journaled a longitudinal screw-shaft 11, which shaft is provided with a continuous right-hand thread extending from the bracket 10 to near the inner bracket 6.

Upon the shaft 11 between the brackets 6, there is mounted a pair of gear-wheels 12 and 13, the former being the outer and the latter the inner ones of the pair. A perforation is formed in the front wall of the bed, immediately above and between the two gears 12 and 13, and in the same a cylindrical casing 14 is fixedly mounted. The casing has its front end open, and its rear end closed but perforated as at 15, for the loose reception and reciprocation of the reduced rear end of a plunger 16. The rear end is threaded and has a limiting-nut 17, adjusted thereon. The plunger at its front end is enlarged to form a head 18, which fits somewhat loosely within the casing 14. An arrow-shaped cam 19 is horizontally-disposed and fixed to the head at the outer end thereof, and a coiled spring 20 is located upon the reduced rear end of the plunger and interposed between the head of the plunger and the rear end of the casing, the tendency of the spring being to normally press the plunger to the front and to return the plunger when pushed to the rear by means hereinafter specified.

In the bearings 8 of the brackets 6 a feed-shaft 21 is journaled, the free end of the same extending to the opposite end of the bed, and

the said shaft is provided for the major portion of its length with a longitudinal groove upon which is keyed a worm-gear 22, the same being designed for longitudinal movement upon the shaft 21. Between the brackets 6 there is mounted a pair of gear-wheels 23 and 24, the former being opposite and engaging with the gear 12 of the shaft 11, and the latter gear 24 engaging not with the gear 13 but with an intermediate gear 25, which in turn engages with the gear 13 the gears 23 and 24 being loose upon the shaft. The gears 23 and 24 have their inner or adjacent faces provided with sockets or cavities 26, and either of said gears is designed to be engaged by a reciprocating clutch 27, which is mounted for rotation with and adapted to reciprocate upon the shaft 21, for which purpose the shaft is provided with a longitudinal feather 28 fitting loosely in a groove formed in the clutch.

To the lower ends of the brackets 6, there is connected a transverse bridge 29, and upon a pin 30 extending laterally from the center of the bridge, there is journaled a rear short lever 31, and an outer longer lever 32. The periphery of the clutch 27 has let therein a band 33, and pivoted to the band by means of a pin 34, is the upper end of said inner lever 31. The outer lever 32 is provided near its center with an oblong transverse opening or eye 35, in which is located an equally wide though shorter block 36; and to said block or in the same the pin 34 is loosely journaled. The upper extremity of the outer lever 32 is provided with a bearing-pin 37, and upon the same there is mounted for loose rotation a roller 38, the track of which is the oppositely inclined cam-faces of the head 19 of the cam-operating plunger. The opposite ends of the oblong opening 35 have threaded perforations 39, and in each of the same is mounted an inwardly-disposed adjusting-screw 40, the opposite inner ends of which serve to limit and adjust the stroke or movement of the block within the opening 35 of the lever; or what would be more properly speaking, serves to limit the oscillations of the vibratory shifting-lever 32.

The inner surface of the apron 4 of the carriage is provided with a pair of bearings 41, located longitudinally opposite each other and near the opposite edges of the apron. These bearings loosely receive and aid in supporting the shifting-bar or rod 42, the inner end of which is pivotally connected by a pin 43 to the vibratory shifting-lever 32, at a point immediately above the clutch. Mounted upon this rod 42, at the opposite sides of the apron, is a pair of stop-sleeves 44. The sleeves are split and have their terminals connected by thumb-screws 45, and are therefore readily adjustable at any point along the bar or rod 42. A shaft 46 is journaled in a transverse perforation 47, formed in the depending apron 4 of the carriage, and secured to the outer end of the shaft is a hand-wheel 48. The shaft is located immediately above the worm 22, and

has mounted loosely thereon a hollow shaft 49, the inner or rear end of which has mounted thereon a gear 50, fixed upon the hollow shaft and therefore loose upon the shaft 46. The rear end of the shaft 46 terminates in a T-head 51 seated in a countersunk recess 52 formed in the rear face of the gear 50, and the opposite ends of the head serve to spread a friction-clutch 53, of U-shape, pivoted between its ends to the bottom of the countersunk recess 52. By turning the hand-wheel 48 the head 51 operated thereby spreads the friction-clutch and thus causes the two shafts 46 and 49 to move together. Between its ends the shaft 49 carries a fixed gear 54, and the same is engaged and driven by the worm 22. A shaft 55 extends inwardly from the apron 4 under the rack-bar 5 of the bed 1, and the same has mounted for loose rotation thereon, a large gear 56, which is engaged and operated by the gear 50, and is provided at its rear side with a toothed hub or pinion 57, which engages with the teeth of the rack-bar 5 aforesaid.

Upon a small stub-shaft 58, extending outwardly from the apron 4, transversely opposite the screw feed-shaft 11, there is mounted for oscillation a disk 59, having a knob or handle 60 and at diametrically-opposite sides of the shaft 58, provided with a pair of rearwardly-disposed pins or rods 61, which extend through openings formed in the apron 4 for their accommodation. These rods each support one section or half of a split-box 62, the said halves or sections having half-round inner faces, interiorly threaded and adapted to constitute a sleeve or nut for closing upon and engaging with the threads of the shaft 11. The outer ends of the pins or rods 61 are, as best shown in Fig. 1, located in the corresponding corners of a pair of eccentric and diametrically opposite slots 63, which are formed in the aforesaid disk 59. From this construction it will be obvious that by rotating the disk through the medium of its handle to the right, the pins are, by the divergence of the free ends of the slots 63, spread and thus the box or nut-sections 62, separated and thrown out of engagement with the threads of the shaft 11. When in this condition, it will be seen that the shaft may rotate without imparting motion to the carriage, or wearing its screw away in the box or nut-section.

The left-hand end of the shaft 21 has mounted thereon a gear-wheel 65, connected by the usual lathe gearing to the cone-pulley shaft or spindle of the lathe.

In operation, the operator after placing the work or shaft to be threaded, accurately determines the length of the thread to be cut, and adjusts the clamping-stops 44 upon the shaft 42, accordingly. The tool is now placed in position, upon the carriage, and the machine is started. The revolutions of the shaft 21 cause motion to be imparted by means of the clutch to the loose gear 24 in the direction

of rotation of the shaft, and from thence motion is imparted to the rear gear 25 and from thence to the gear 13, which through the medium of the intermediate gear 25, is caused to rotate in the same direction as the gear 24, so that the gear 13 being fixed upon the shaft 11, the said shaft is rotated in the same direction as the shaft 21. The above operation of course takes place only when the clutch 27 is in engagement with the gear 24, whereby the latter is made fast upon the shaft 21. The shaft 11 rotated to the right, it will be seen through the medium of the threaded nut or sleeve 62, causes the carriage to move along its ways toward the left of the machine. When the carriage has moved sufficiently far, one of the bearings 41, which support the rod 42 and which have their outer faces projecting beyond the edges of the apron, come in contact with the clamping-stop at the left side of the carriage, and which as before stated has been fixed upon the rod or bar 42, and in this manner the rod is reciprocated toward the left end of the machine and with it the shifting-lever 32. The upper end of the shifting-lever, which as before stated carries a friction-roller, moves over the inclined face of the head of the cam-plunger, the latter receding against the tension of its spring, until the upper end of the lever has passed beyond the center of the arrow-shaped cam-head of the plunger, when the spring suddenly throws the cam forward and the lever is shifted or thrown to the left. When the shifting lever 32 has reached or nearly reached the point of the cam, it begins to act upon the block 36, and hence withdraws the clutch from its engagement with the gear 24, so that by the sudden shifting of the lever, it is completely withdrawn from engagement with the gear 24, and thrown into engagement with the gear 23, so that the gear 24 now being the loose gear revolves idly upon the shaft 21, while the gear 23 becomes the fixed gear and imparts its motion direct to the gear 12, and thus rotates the shaft 11 in an opposite direction or to the right, so that the carriage is fed back to the starting-point. When the carriage reaches this starting-point, it contacts with the stop at the opposite end of the shifting-rod 42, thus drawing the rod to the right and through the medium of the shifting-lever 32, throwing the clutch back into engagement with the gear 24, which again becomes fixed and imparts its motion to the gears 25 and 13, and thus rotates the shaft again to the left, so that though the motion be continuous in one direction of the shaft 21 and gear 65, it will be seen that the carriage will be moved in first one direction and then the other, between a predetermined space, and that the shifting will be entirely automatic, thus saving the trouble of unshipping the tool and returning the carriage by hand at the end of each travel, to again take up the thread.

When it is desired to use the lathe for general purposes and not for screw-cutting, the

disk 59 is partially rotated so as to release the screw-shaft 11 from engagement with the nut 62, and hence any rotation of the shaft will not be imparted to the carriage, and while the latter will be free to be used as desired, we save unnecessary wear upon the screw-shaft and are not required to ship and unship the belts by which the gear 65 is operated. It will be seen that the carriage may be instantly thrown into operative connection with the shaft 11, by a simple partial rotation of the disk 59, which is right at the hand of the operator. When the carriage is disconnected from the shaft 11 and it is desired to feed the same to any point in the ordinary manner, the hand-wheel 48 is given a turn so that its head 51 spreads the friction-clutch 53, and thus fixes the gear 50 tight upon the shaft 46. The worm-shaft 21 continuing its revolutions, imparts motion by its worm 22 to the gear 54, and from said gear motion is imparted to the gear 50 through the medium of the shaft 49, with which the gears 54 and 50 are rigid. Motion is imparted from the gear 50 to the large gear 56, and from this gear to the hub thereof, 57, which as shown in Fig. 10, is always in engagement with the rackbar 5 of the lathe bed. Thus the carriage is fed to any point along the bed, by gear 65. A belt drives the cone of the lathe, the latter driving a fixed gear on spindle, thus rotating the shaft thereof, and an outer gear it carries. This latter gear operates an intermediate gear, and the latter meshes with and operates gear 65, the intermediate gear is thrown into and out of engagement with the gear 65 by a lever, all as is usual in lathes and as shown by dotted lines in Fig. 1. The carriage may be stopped at any point by simply giving the wheel 48 a partial rotation. When the carriage is thus used, the clamping-blocks will have been loosened upon the shifting-rod or bar, so as not to influence the shifting-lever 32, and the latter will have been swung to a vertical position between the two sets of gears 12 and 13 and 23 and 24, so that the upper end of the lever rests upon the point of the cam, and the clutch is not in engagement with either the gear 23 or the gear 24.

It will be obvious that in lieu of securing the mechanism heretofore described, to the front wall of the lathe-bed such mechanism may be supported above the lathe, and for the purpose of illustrating the same, reference is had to Figs. 12, 13 and 14 of the drawings. In these figures, a suitable frame 66 is bolted to the ceiling, and from the same depends a U-shaped frame 67. A shaft 68 journaled transversely in the upper end of the U-shaped frame, carries the two fixed gears 69 and 70, and has one end extended beyond said U-shaped frame, and journaled in a hanger 71, between which and the U-shaped frame a cone-pulley 72 is mounted. A second shaft 73 is journaled in the U-shaped frame below the shaft 68, and beyond the frame carries a band-wheel or pulley 74. Loose

gears 75 and 76 are located on the shaft 73, and between said gears there is splined or feathered on the shaft 73 a reciprocating-clutch 77, designed to be thrown into engage-  
 5 ment with either of the gears 75 or 76, and thus render that gear with which it engages fixed with relation to the shaft 73. A pin 78 projects from the clutch, and is loosely engaged by the upper slotted end 79 of a lever 80,  
 10 fulcrumed as at 81 to the lower end of the U-shaped frame, and extending down to a point above the lathe, where it may be grasped by the operator and shifted from one side to the other. Motion is communicated from the gear 70 to the  
 15 gear 76, through the medium of an intermediate gear 82, which is mounted on a shaft 83, journaled in the frame 67 between the shafts 68 and 73. The yoke 84, which engages the clutch, and to which the lever 80 is pivoted, is mounted  
 20 for reciprocation on a shifting rod or shaft 85, located in bearings 86 projecting from the front of the frame 67, opposite the shaft 73. It will be understood that when this mechanism last described is employed, only the shafts  
 25 21 and 11, the carriage mechanism and the gear for the worm-shaft, are applied to the base or bed of the lathe, and motion is communicated by belt from main shaft to pulley 74, and from cone 72 by belt to cone, as will  
 30 be readily apparent. The operation is substantially the same as that heretofore described, with the exception that it is necessary to shift the lever 80 by hand instead of automatically, as heretofore described. The  
 35 shaft 68 revolves in one direction only, communicating motion through the medium of its gear 69 to the gear 75 of the shaft 73, and if the clutch be in engagement with this gear the shaft 73 is revolved in the direction in  
 40 which the gear 75 is driven. By shifting the lever 80, however, to the opposite side, so that the clutch 77 is in engagement with the gear 76, the gear 75 becomes an idle gear, and the gear 76 the working gear, and hence by  
 45 reason of the intermediate gear 82, the gear 76 and the shaft 73 are rotated in an opposite direction, to their former direction of rotation.

From the foregoing description, in connection with the accompanying drawings, it will  
 50 be seen that we have provided an improvement in lathes whereby the same are adapted to cut screws with facility, and the carriage may be reversed either by hand or automatically.

55 Having described our invention, what we claim is:—

1. The combination with a lathe-bed, and a carriage mounted for movement thereon, of a threaded feed-shaft connected with the carriage, a pair of gears fixed upon the shaft, a  
 60 second shaft located below the feed-shaft, loose gears mounted thereon, one of which is engaged by the corresponding gear of the feed-shaft, a gear located between and connecting the two remaining gears of the two  
 65 shafts, a clutch splined upon the second shaft between its gears and adapted to engage with

either, means for operating the said second shaft and means for shifting the clutch from one loose gear to the other, substantially as 70 specified.

2. The combination with a lathe-bed and a carriage mounted for movement thereon, of a threaded feed-shaft connected with the carriage, a pair of gears fixed upon the shaft, a  
 75 second shaft located below the feed-shaft, loose gears mounted thereon, one of which is engaged by the corresponding gear of the feed-shaft, a gear located between and connecting the two remaining gears of the two  
 80 shafts, a clutch splined upon the second shaft between its gears and adapted to engage with either, means for operating the said second shaft, a pivoted shifting lever connected at one side of its fulcrum with the clutch, and  
 85 devices between the shifting-lever and the carriage whereby the former is operated by the latter, substantially as specified.

3. The combination with a lathe-bed and a carriage mounted for movement thereon, of a  
 90 threaded feed-shaft connected with the carriage, a pair of gears fixed upon the shaft, a second shaft located below the feed-shaft, loose gears mounted thereon, one of which is engaged by the corresponding gear of the  
 95 feed-shaft, a gear located between and connecting the two remaining gears of the two shafts, a clutch splined upon the second shaft between its gears and adapted to engage with either, means for operating the said second  
 100 shaft, and devices for shifting the lever, said devices being operated by the carriage by being arranged in the path of the same, substantially as specified.

4. The combination with the lathe-bed, and  
 105 the carriage mounted for reciprocation thereon, of an upper and lower shaft, journaled in the bearings in front of or back of the bed, the upper shaft being threaded to constitute a feed-shaft, a pair of gears spaced apart and  
 110 mounted fixedly upon the feed-shaft, a pair of loose gears mounted on the lower shaft, power-applying devices mounted on said shaft, a sliding clutch adapted to engage with either of said loose gears, splined upon said lower  
 115 shaft, a shifting-lever pivoted below and between the pairs of gears, and having an eye engaging a block on the clutch, a spring-actuated plunger located above the clutch and provided with an arrow-shaped head against  
 120 which the upper end of the shifting-lever rides a shifting-rod connected with the shifting-lever and actuated by the movements of the carriage, substantially as specified.

5. The combination with the lathe-bed, and  
 125 the carriage mounted for reciprocation thereon, of an upper and lower shaft, journaled in the bearings in front of or back of the bed, the upper shaft being threaded to constitute a feed-shaft, a pair of gears spaced apart and  
 130 mounted fixedly upon the feed-shaft, a pair of loose gears mounted on the lower shaft, power-applying-devices mounted on said shaft, an intermediate gear connecting two of the

gears and the upper and lower shafts, the remaining gears intermeshing, the shifting-lever pivoted below and between the gears of the lower shaft and terminating at its upper end in a friction-roller, a clutch splined upon the lower shaft and adapted to engage either of its gears, a second lever mounted upon the bearing-pin of the shifting-lever and having a block formed on its front face, taking into an oblong eye of greater length formed in the shifting-lever, adjusting-screws located at the opposite ends of the eye to limit the movement of the block, a pin extending from the clutch through the block, a shifting-rod connected loosely with the shifting-lever and supported in bearings located upon the apron, clamps provided with set-screws located upon the shifting-rod at opposite sides of the apron and adapted to serve as stops, the casing located in the front wall of the bed above the upper shaft, the headed plunger mounted for reciprocation in the casing and having its rear reduced end extended through the casing and provided with an adjusting-nut, a coiled spring encircling the rear reduced end of the plunger, and interposed between the head of the plunger and the end of the casing, and the arrow-shaped cam located in the head of the plunger and having its opposite inclined edges forming tracks for the friction-roller located at the upper end of the shifting-lever, substantially as specified.

6. The combination with the lathe-bed having the rack-teeth 5 and the carriage having the depending apron, of the shaft 21 having

the worm gear 22 adapted to slide thereon, the shaft 46 mounted in bearings 47 and crossing the worm, the hollow shaft 49 mounted on the shaft 46 and having the gear 54, the handle on the outer end of the shaft 46, the recessed gear on the inner end of the shaft 49, the friction-clutch 53 located in the recessed gear, the spreader 51 located on the inner end of the shaft 49, the upper shaft 55 journaled in the apron, carrying the main gear 56 and the hub 57, toothed to engage with the gear 5 of the bed, substantially as specified.

7. The combination with a lathe-bed, reciprocating carriage, and feed-screw, of a lower shaft carrying loose gears, fixed gears upon the feed-screw, two of said gears meshing directly and the other two through an intermediate gear, means to rotate the lower shaft, a clutch arranged upon the lower shaft to engage either loose gear, a shifting lever transversely slotted to receive a block upon the clutch, whereby the lever is allowed a limited play independent of the clutch, and a rod connected to the lever and carrying stops arranged in the path of the carriage, substantially as specified.

In testimony that we claim the foregoing as our own we have hereto affixed our signatures in the presence of two witnesses.

GIDEON R. IBACH.  
JOHN H. SCHULTZ.

Witnesses:

DAVID SCHULTZE,  
JOHN H. HENNINGER.